

Programme

```
#picaxe 08M2
```

```
dirsc=%00000100  
symbolTSOP=pinc.3
```

```
debut:  
if tsop=0 then  
servo c.2,100  
servopos c.2,100  
wait 1  
servopos c.2,150  
wait 1  
servopos c.2,100  
servo c.2,off  
endif  
goto debut  
end
```

Montage

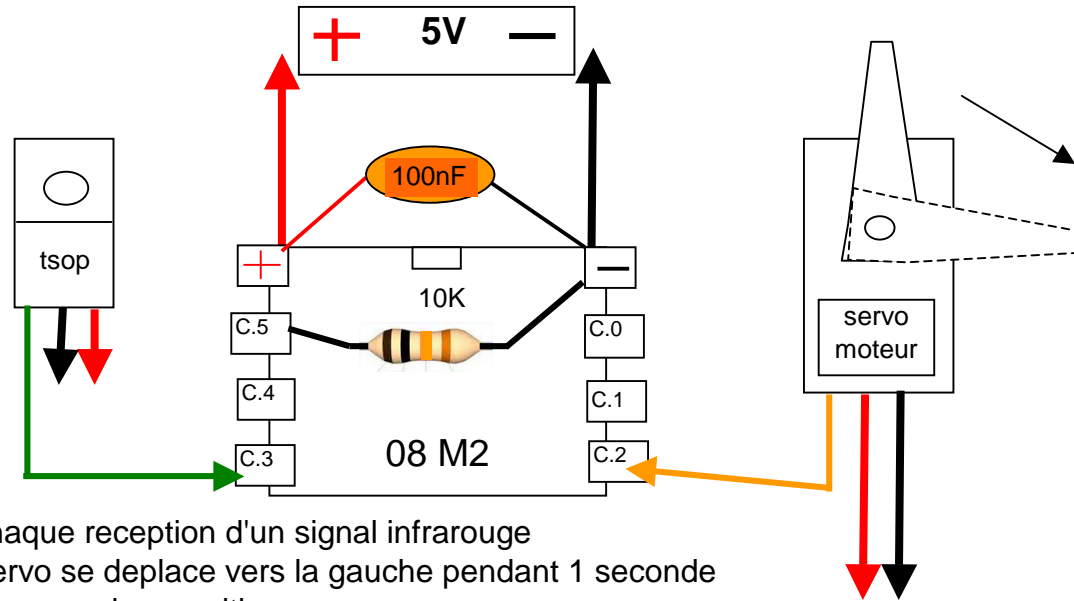

A chaque reception d'un signal infrarouge
le servo se deplace vers la gauche pendant 1 seconde
puis reprend sa position